

High Voltage Power Supply's

THESE PSU'S ARE NO TOY'S. KNOW WHAT YOU ARE DOING, AS THEY CAN KILL YOU.

MAKE SHURE THE POWER SUPPLY IS DISCONNECTED FROM THE MAIN AND THERE IS NO VOLTAGE INSIDE. LEAVE IT FOR AT LEAST 5 MINUTES AFTER DISCONNECTING IT FROM THE MAINS BEFORE CONNECTING IT.

DO NOT OPEN IT, THERE ARE NOT USER-SERVICEABLE PARTS INSIDE !

General technical specifications

Main input	Voltage	220 Vac 50 Hz (110 Vac upon special order)	
	Surge current	$\leq 60\text{A}$ (220 Vac input)	$\leq 30\text{A}$ (110 Vac input)
	Leak current	$\leq 0.7\text{mA}$ (220 Vac input)	$\leq 0.4\text{mA}$ (110Vac input)
Efficiency	$\geq 90\%$ (at full load)		
Response time	$\leq 1\text{ mS}$ (from switch signal to output current risen to be 90% of set current)		
Control input	TTL control (see figure X)		
Work conditions	Ambient temperature $-10\text{ }^{\circ}\text{C}$ to $+40\text{ }^{\circ}\text{C}$, relative humidity: $\leq 90\%$		
Cooling	Forced air with internal blower		

Type related technical specifications

Type	Vout (KV)	Iout (mA)	Width (mm)	Height (mm)	Depth (mm)
XX-500	25	20	144	91	207
XX-800	35	23	144	91	207
XX-1120	40	28	173	97	280
XX-1900	50	38	240	95	325
XX-3500	35	100	256	95	340

Connecting instructions

a) **MAKE SHURE THE POWER SUPPLY IS DISCONNECTED FROM THE MAIN AND THERE IS NO VOLTAGE INSIDE. LEAVE IT FOR AT LEAST 5 MINUTES AFTER DISCONNECTING IT FROM THE MAINS.**

b). Connect the co2 laser tube's anode to the PSU-500 high voltage terminal (HV+). Connect the co2 laser tube's cathode to the PSU-500 ground. MAKE SHURE THEY ARE CONNECTED AND ISOLATED. (arc)

c). Connect the control signals (refer to figure Y).

Connect the control signals to the PSU-500 control terminals as shown in figure Y, and make shure ALL GROUNDS ARE CONNECTED.

d). Connect WP (Water Protection) input. There is a protection input on PSU-500 (WP), which can be used to protect the system against low water flow, low air flow, open case, or whatever you wish to protect.

e). Check if the input voltage is appropriate, and make shure GND is connected.

f). Check everything again, especially the separation of the high voltage side against the low voltage side, and all grounds.

g) Turn on the PSU. If the warning light is lit, check all wires (including input voltage and control signals). If the power output is controled by PWM, check if the PWM frequency is above 20KHz and the peak - peak value is 5V or less. Finally check if the WP (Water Protection) input is connected correctly.

ATTENTION

- The high voltage output may never be left open, as this will arc and destroy the PSU.
- After switching the PSU off, there will still be LEATHAL VOLTAGES inside and outside the PSU (including to a connected laser tube). ALWAYS LEAVE THE PSU FOR 5 MINUTES AFTER DISCONNECTING IT FROM THEM MAIN, AND AFTER THE 5 MINUTES SHORT-CIRCUIT THE OUTPUT TO GROUND if you need to work on the PSU. CHECK AND DOUBLE CHECK THE OUTPUT VOLTAGE. KNOW WHAT YOU ARE DOING, AS THIS PSU CAN KILL YOU.
- PSU-500 has a 3 input terminal for a main connector (110 or 230 Vac). For safety, make shure the PSU is properly connected to ground.

PSU Outline

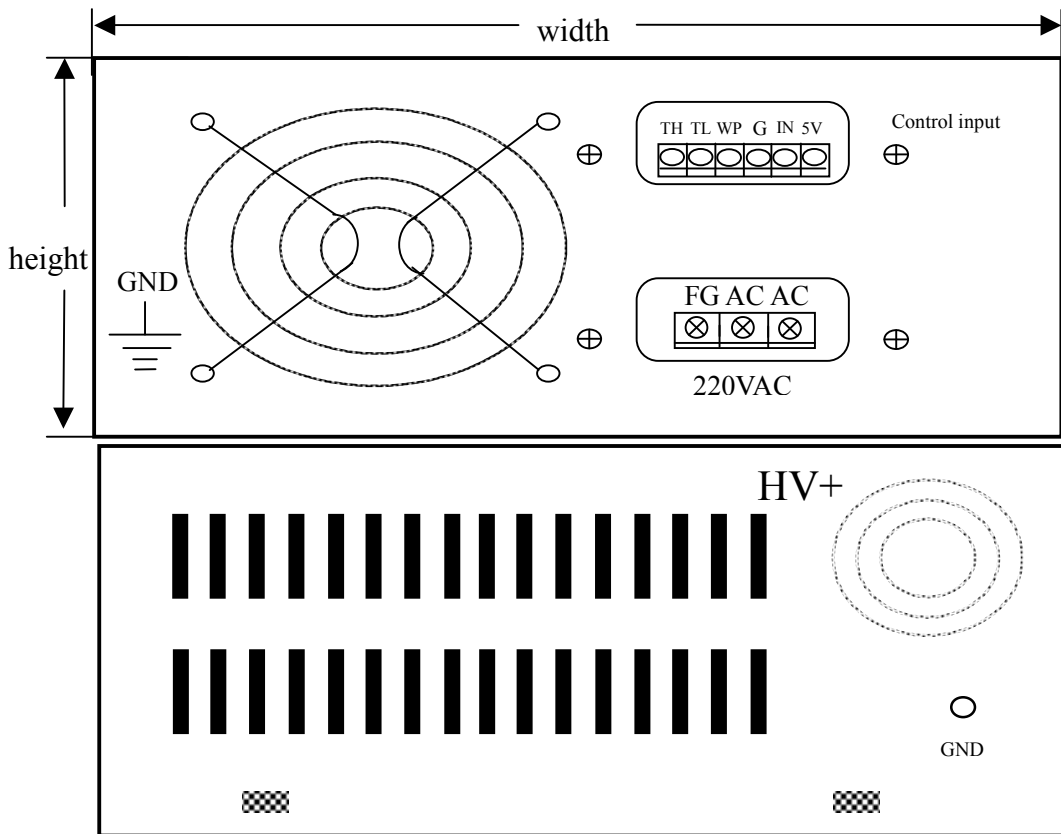
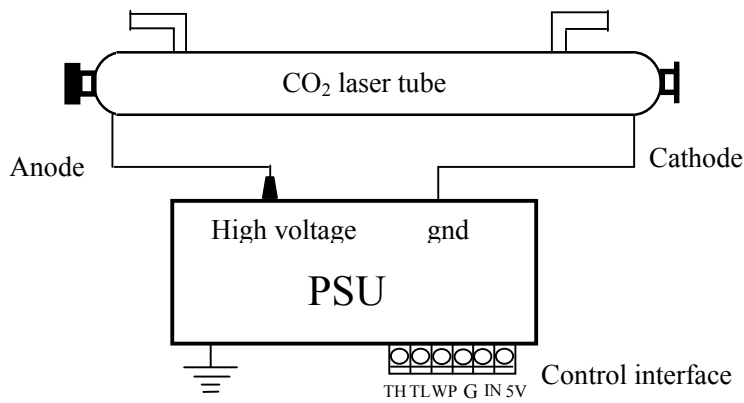
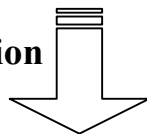

Figure 1



Terminal connection



TH	TL	WP	G	IN	5V
----	----	----	---	----	----

Figure 2

Digital Control Connections Levels.

TH	Input	Opto input, high level ($\geq 3V$) on , low level ($\leq 0.3V$) off
TL	Input	Opto input, high level ($\geq 3V$) on , low level ($\leq 0.3V$) off
WP*1	Input	Opto input, high level ($\geq 3V$) on , low level ($\leq 0.3V$) off
G	Ground	Ground, make shure it is connected to all other grounds.
IN*2	Input	Power output level control, controlled by either a 0-5V analog signal, or a PWM signal.
5V	Output	5V reference output, max. drawn current must be less then 20mA.

Figure 3

Digital control input truth table

TH	TL	WP	IN	OUTPUT
L	X	X	X	Off
X	H	X	X	Off
X	X	H	X	Off
H	L	L	0 Vdc	Pmin
H	L	L	5 Vdc	Pmax
H	L	L	PWM	Pmin - Pmax

Figure 4

Connection example

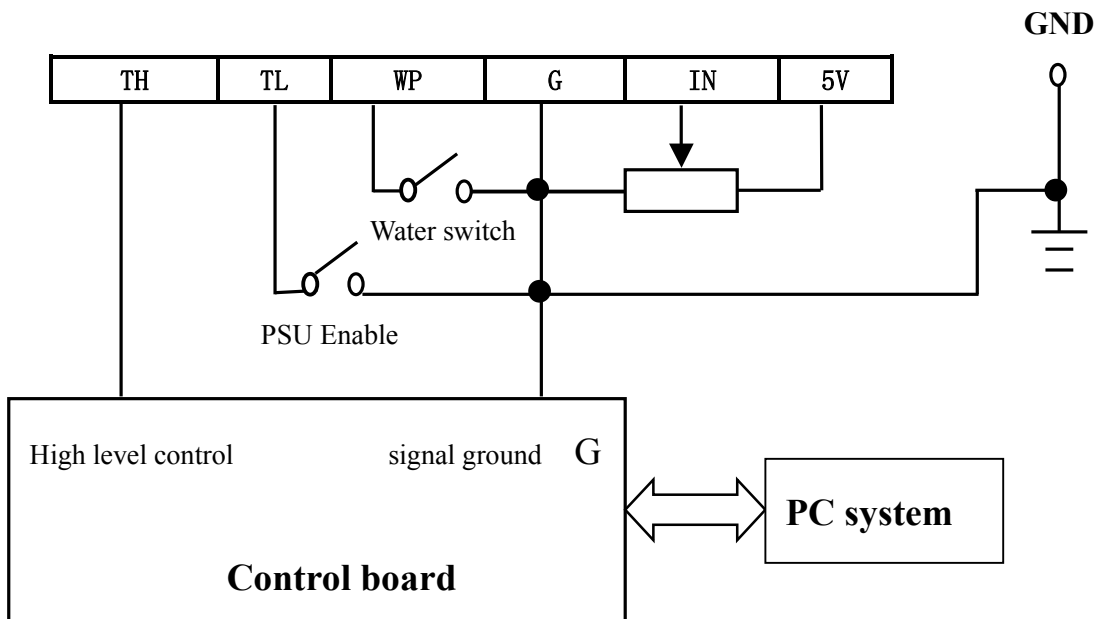

Figure 5

Test connection example

This will fire the PSU with maximum power upon connection to the main, so be careful !

(make shure HV output is connected).

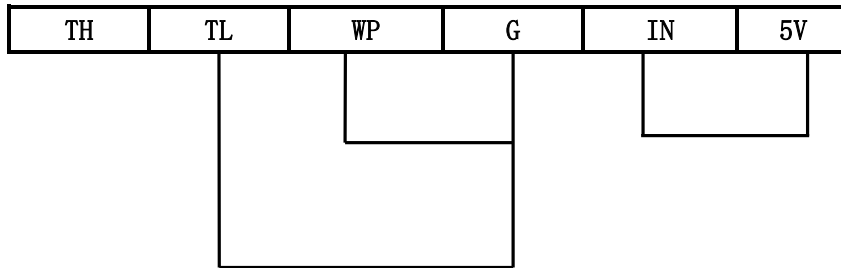

Figure 6